

SCOOT

The model handles well and has a good turn of speed and duration for so simple a model.

36

Rob Cairns offers plans for a simple fast electric runabout.

Scoot is a simple and elegant two function radio controlled electric model boat. The compact design enhances her speed and manoeuvrability and her lightweight fabrication ensures rapid acceleration up to planing speed. Construction of the model can be undertaken in the most diminutive workshop and transportation is of course no problem.

She is of 450mm length and about 1kg in all up weight, which makes her ideal in size for many modellers as a fun boat to add to the car boot as light relief from more complex models.

Hardware And Materials

- 175mm. long drive shaft assembly
- 35mm. long universal joint
- 35mm nylon prop
- 40mm. brass rudder assembly
- 540 electric motor (preferably 3 pole)
- 27Mhz receiver
- 2 x standard servos
- 500 mAh receiver pack
- Bob's Models Varispeed PB8 speed controller
- 7.2 volt/1200 mAh power pack

The balsa panels all in place, with spray strips in position. All sanded and filled ready for painting.

Construction is almost entirely of balsa wood. Use of mini servos and a smaller receiver pack would further enhance performance by reducing the model's total displacement.

The Hull

The prototype was largely assembled using balsa cement. (Note - parts that cannot be easily reached after construction must be sealed with sanding sealer beforehand).

Cut out the deck pieces and the keel sections from 3mm. balsa and the four formers (F1 to F4) from 4mm. balsa. Note that F2 has a hole cut in the centre which meets the keel slot, such that the lower parts of the former are not joined in any way. Glue the deck pieces together on

6mm. square stringer each side). Now sand down the keel and stringers to the correct shape, ready for the under surface sheeting.

Start at the rear of the boat, sheeting the under surface with six panels of 2mm. balsa, the grain running along the hull to allow the wood to form the necessary curves. The panel join-lines occur at the keel and at each former. Strength (and the quality of finish) can be improved by skinning the lower surfaces with lightweight glass-cloth impregnated with epoxy resin. Next the 3mm. side pieces are glued into position (grain vertical). Note the cross-sectional views of the hull, in particular, how the 3mm. balsa side panels fit against the 2mm. hull sheeting, as this changes 40mm. ahead of the former F3). Add the block balsa pieces for the bow and stern and sand them to shape. Now is a good time to build a stand, if you haven't already done so.

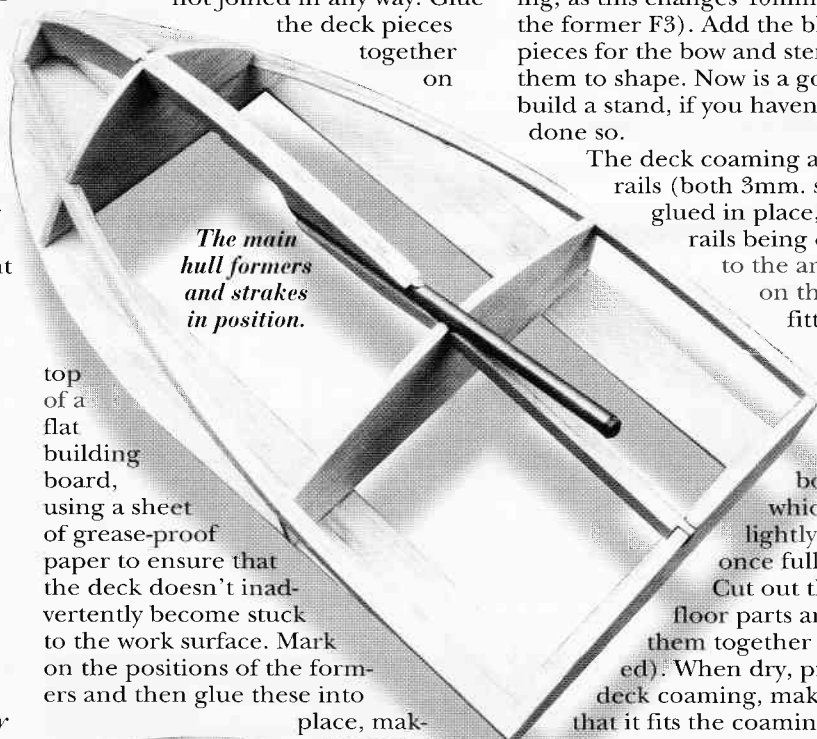

The main hull formers and strakes in position.

top of a flat building board, using a sheet of grease-proof paper to ensure that the deck doesn't inadvertently become stuck to the work surface. Mark on the positions of the formers and then glue these into

place, making sure that they are all at 90 degrees to the deck.

Next glue the keel parts and propshaft in place using five minute epoxy. Glue the keel doublers into position, then glue the 3mm by 6mm stringers (two each side to effectively create one

The deck coaming and spray rails (both 3mm. square) are glued in place, the spray rails being chamfered to the angle shown on the plan, after fitting. Finally, any imperfections in the hull are filled using car body filler, which is then lightly sanded once fully cured.

Cut out the cockpit floor parts and glue them together (butt-jointed). When dry, pin this to the deck coaming, making sure that it fits the coaming shape exactly. Glue the cockpit sides to the floor ensuring that the whole assembly can be removed from the hull when set. Glue 3mm. square reinforcing strips between the floor and the sides followed by the rest of the cockpit panels. The cockpit roof is made of several sections butt-jointed together. It is easiest to cut these sections slightly wide and assemble them directly on top of the cockpit, sanding them flush with the sides once the glue has set. Finally, a hole is cut in

The original model used a Bob's Board speed controller, but an electronic one would fit easily, at slightly greater expense.

the cockpit floor (75mm. x 250mm.) to reduce the weight of the superstructure above the centre of gravity and also eliminate a possible water trap.

Finishing

If using lightweight glass-cloth impregnated with epoxy resin on the lower surfaces ensure that the resin is applied in a warm environment so that it cures correctly. During application, a stippling action with a brush succeeds in removing unwanted air bubbles, while moistened, fine, wet and dry paper is used to produce an ultra smooth finish once the resin has set.

The outer surfaces of Scoot is covered with tissue and dope, giving a strong but lightweight structure. The prototype model was painted in Finnigan's "Smoothrite", which was then allowed to cure. The use of fine 'wet and dry' paper succeeded in producing an ultra smooth surface and finally, the entire model was sprayed with enamel paint to give an excellent shiny finish. (Note: try to match the colours of the Smoothrite undercoat and enamel top coat as closely as possible).

Equipment Installation

The motor is mounted on a shortened commercial "L"-shaped metal bracket, which is screwed to a 2mm. plywood plate epoxied to the bottom of the hull. The rudder is a commercially available unit, which for the prototype needed the control arm shortening in order to fit it into the confined space allotted to it.

It is essential to use a universal joint between the motor and the propshaft in order to protect the bearings of the motor. The joint should be no longer than 35mm., however, if you can only obtain a larger unit, it is sometimes possible to remove the metal adaptors at each end, cut down the nylon body to the required length and then refit the adaptors, ready for installation.

A hole is drilled for the rudder post, which is then bolted into position. The rudder itself is installed after the

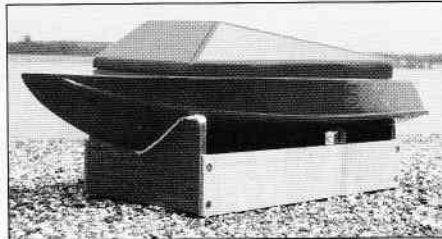

Scoot on her stand, the paint job making her basic shape very appealing.

motor and propshaft assembly are in place. All radio gear is installed using servo tape. Before running the boat, seal the joint between the cockpit and deck coaming with a fillet of Vaseline.

Water Trials

Before going out to test the model, float it in a bath to check for leaks, ensure that the prop turns in the correct direction and give the radio gear a range check with the motor running.

All trials were undertaken using a 7.2 volt 1200 mAh power pack and "Bob's Models" speed controller. The distribution of the equipment was altered during the course of testing to adjust the longitudinal centre of gravity position and obtain the desired performance. The recommended position is indicated on the plan.

Initially a standard "380" electric motor was used and Scoot was found to be uninspiring - a real "Sunday Afternoon Drivers" model. Despite excellent manoeuvrability boredom soon set in, made worse by the lengthy running time of such a frugal motor. Back to the workbench for a "540" refit!

With its new power plant Scoot lives up to its name. Rapid acceleration up to a fast planing speed soon attracts the usual brigade of pre-adolescent kids, their cliched catchphrase of "cor mister how much did that cost?" ringing in my ears. Smooth, tight turns are a delight to behold, though skill is required to maintain a fast line, since excessively sharp manoeuvres

SKETCH 1.

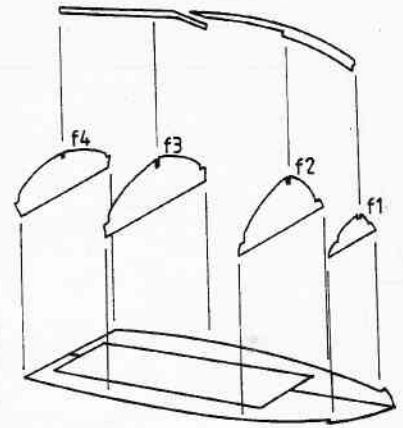

SKETCH 2.

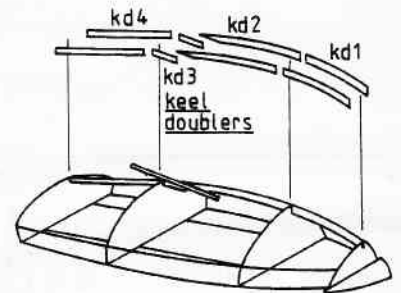

SKETCH 3.

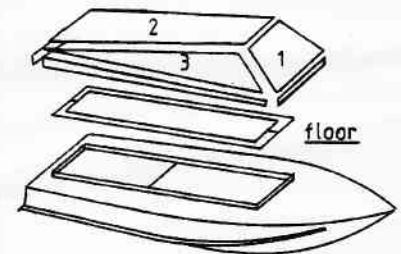

can cause the propeller to surface momentarily, briefly reducing forward speed.

For an inexpensive nippy little electric boat, Scoot has exceeded all my expectations. If you choose to make this little rascal I'm sure it will give you plenty of fun. Happy Scooting!

Thanks

To my wife Carol for her help in producing this feature, and to my father for a sterling rescue operation following an early mechanical failure!

The Scoot from the stern.

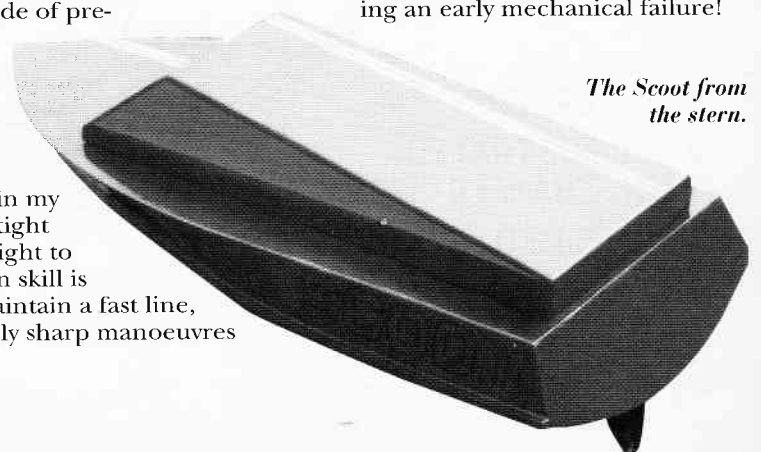

Sketch 1

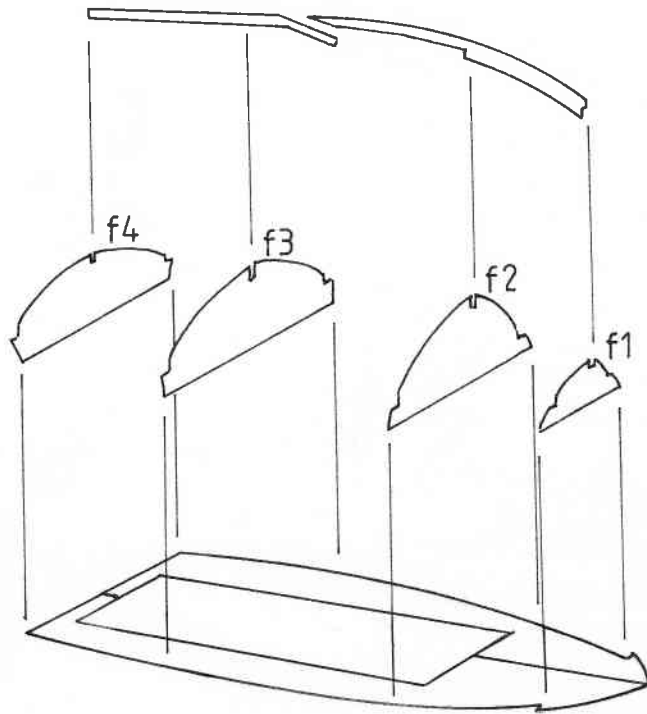

Sketch 2

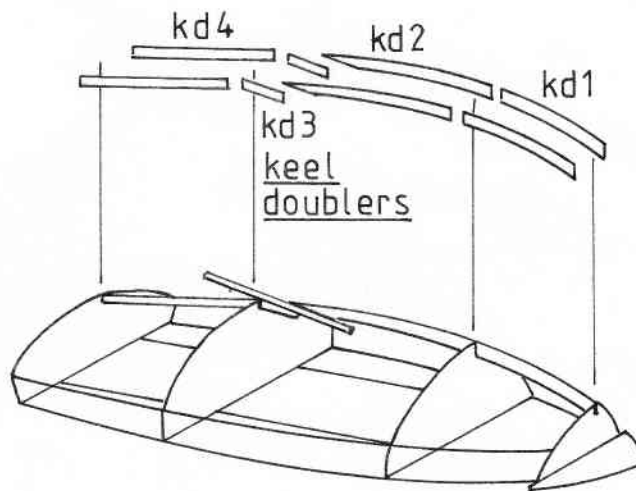

Sketch 3

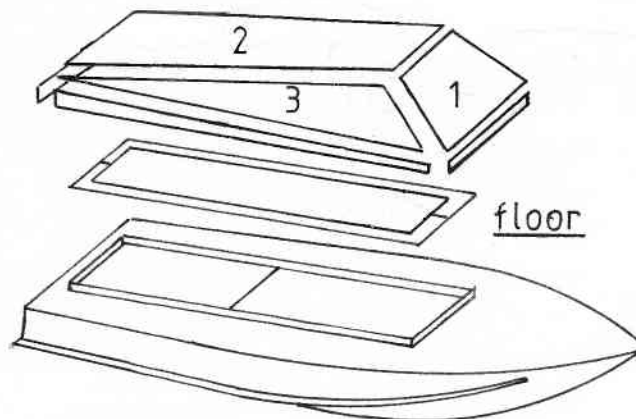

FORMERS

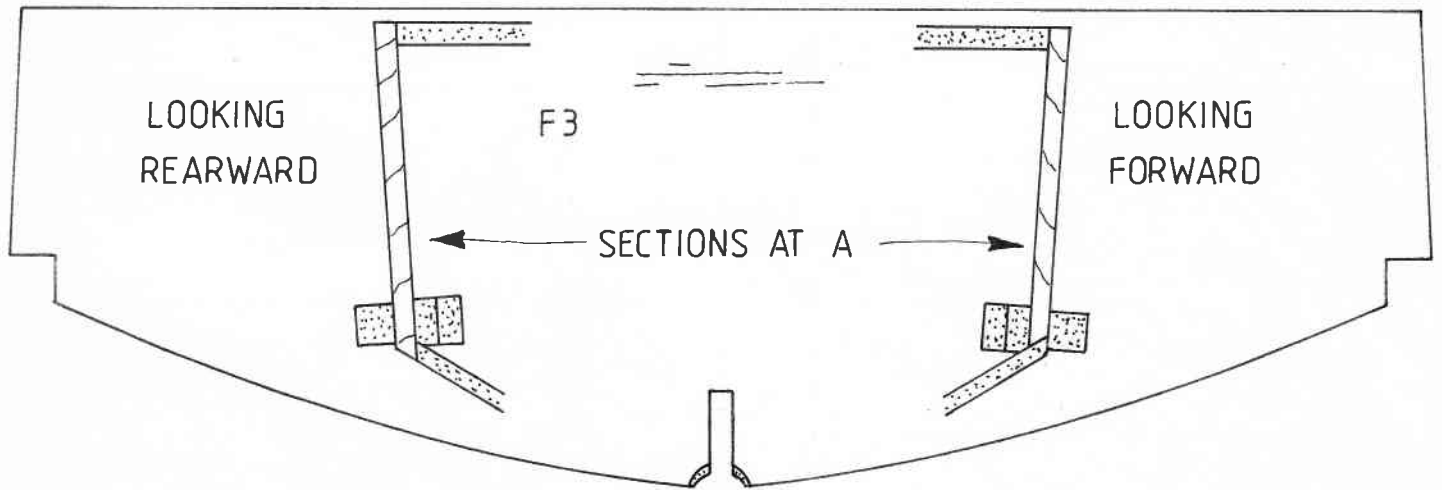
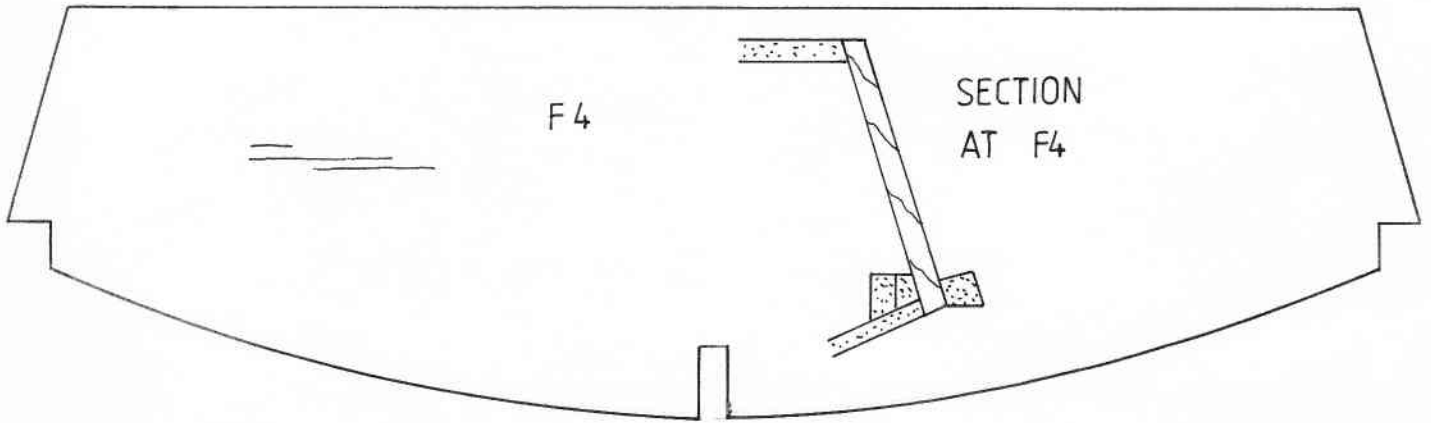

1/4" x 1/8" STRINGERS
(TWO EACH SIDE)

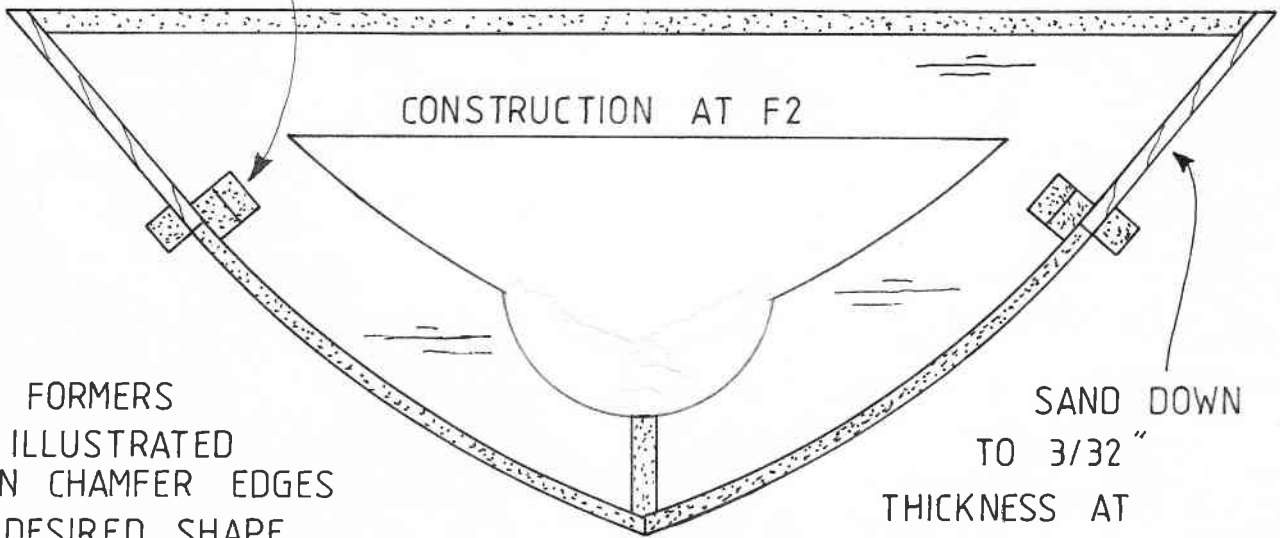

CUT FORMERS
AS ILLUSTRATED
THEN CHAMFER EDGES
TO DESIRED SHAPE

SAND DOWN
TO 3/32"
THICKNESS AT
FRONT

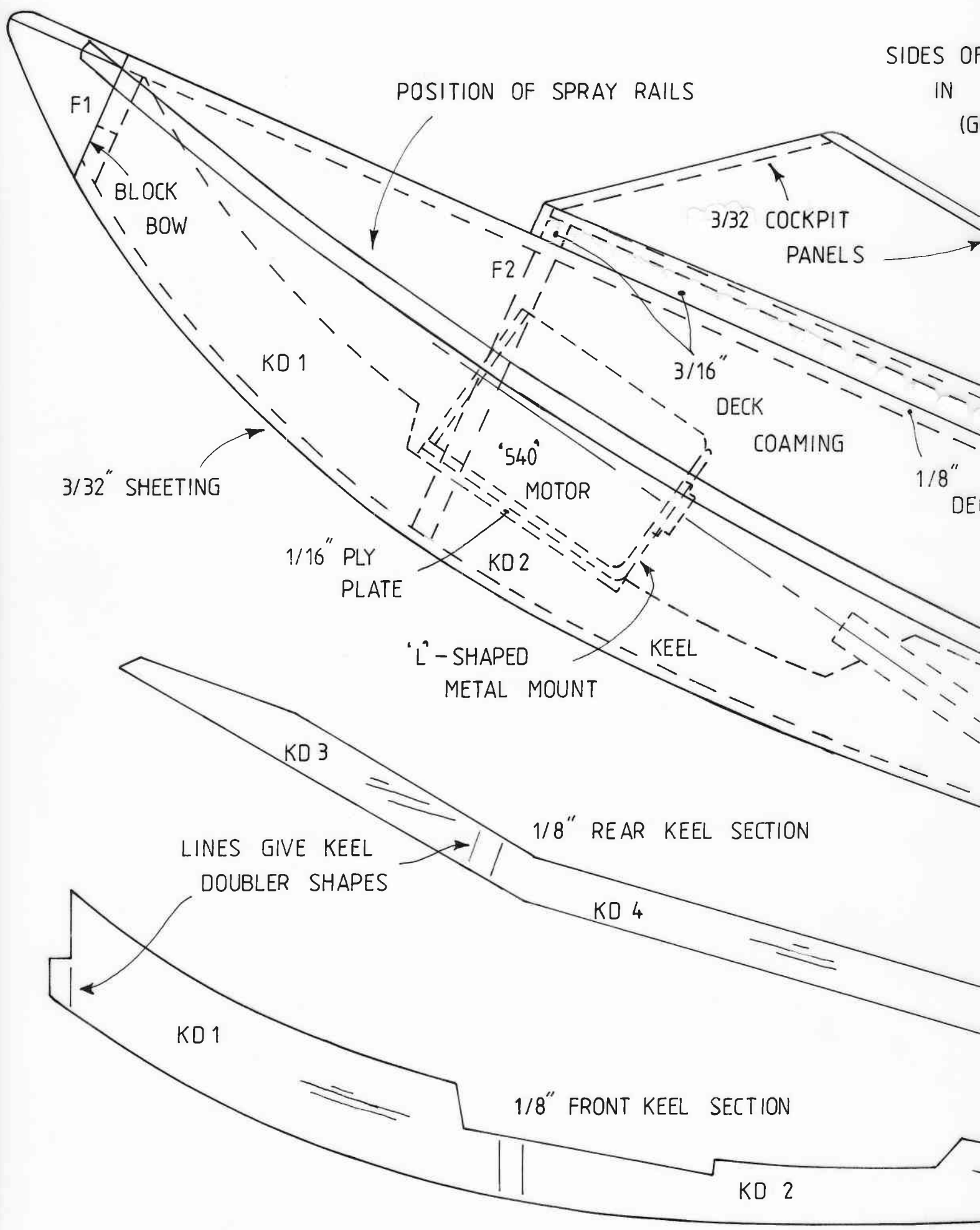

DES OF HULL ARE SHEETED
IN 1/8" Balsa
(GRAIN VERTICAL)

SCOOT

R/C ELECTRIC BOAT ROBERT S. CAIRNS

ALL WOOD IS Balsa UNLESS
OTHERWISE STATED. ALL
FORMERS ARE 3/16"

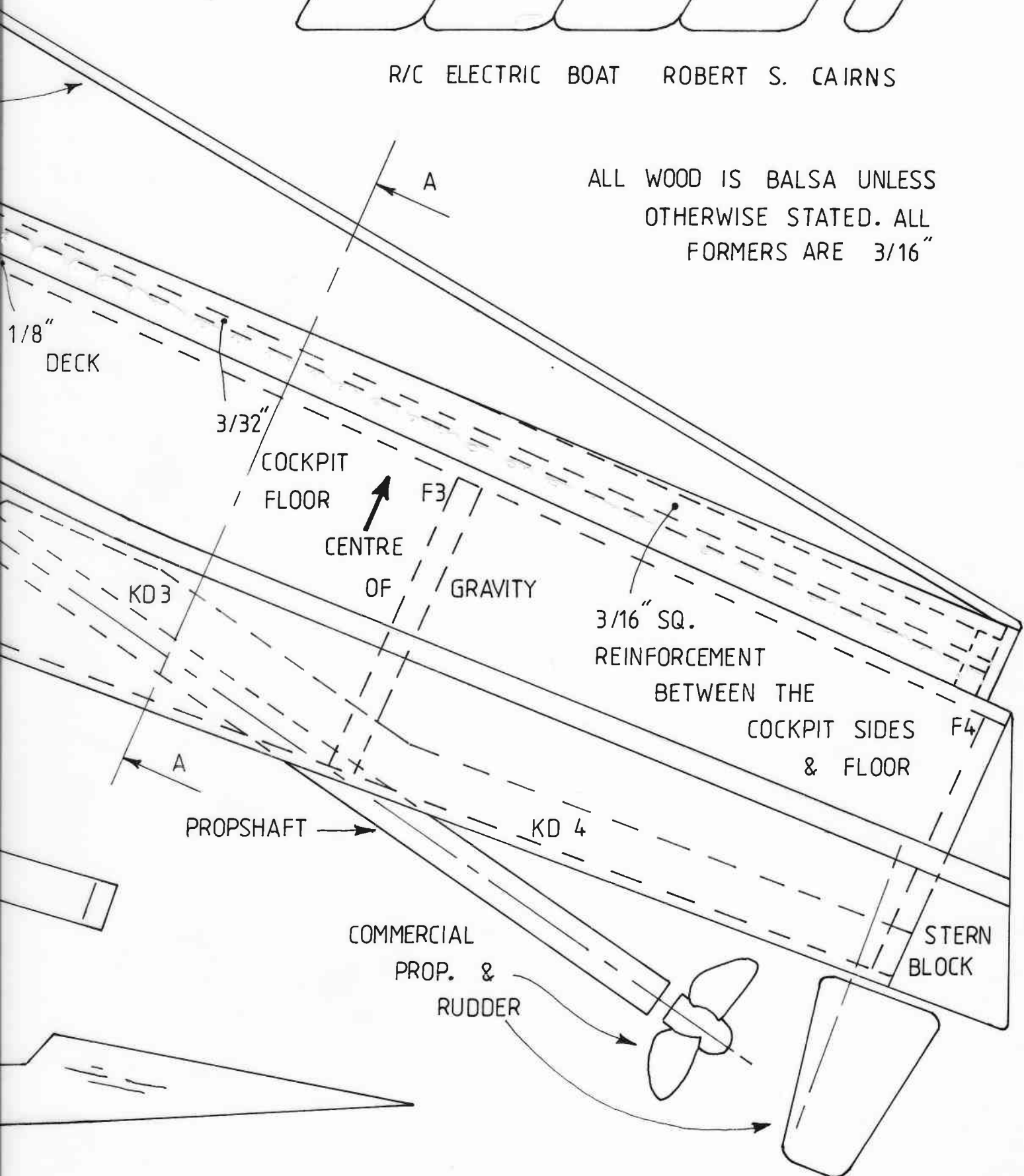

COCKPIT PART 3 (x 2)



DIRECTION OF GRAIN
GIVEN BY 

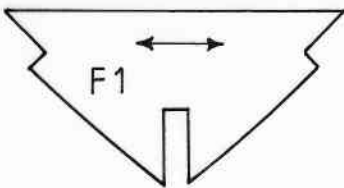

DECK HALF 

FORMER
POSITIONS



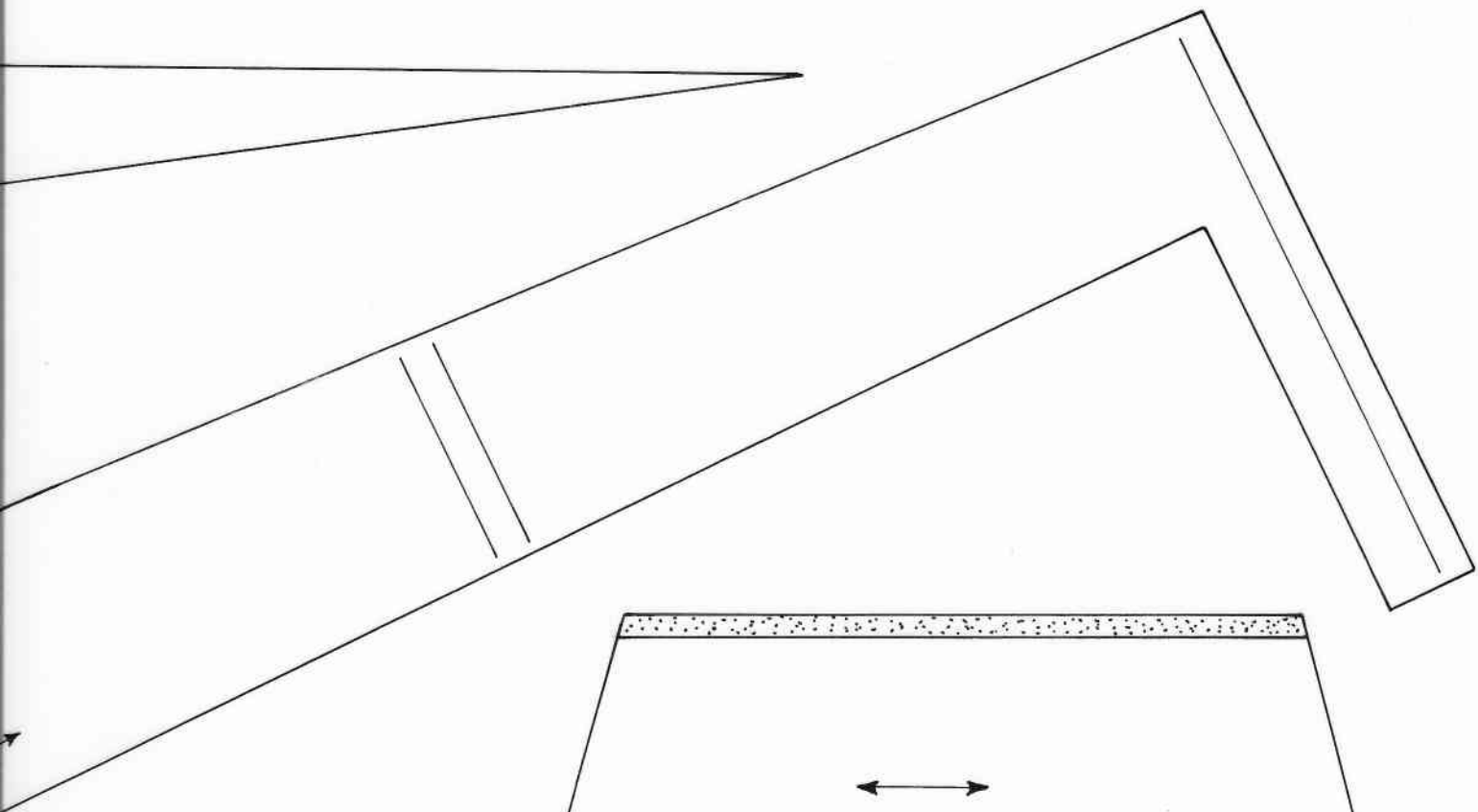

COCKPIT PART 1

COCKPIT PART 2